

## 1.2 Oil Pressure Sensor

Oil Sensor	Mk8 MM
Green (2)	T35
Blue (3)	T48
Red (1)	T49

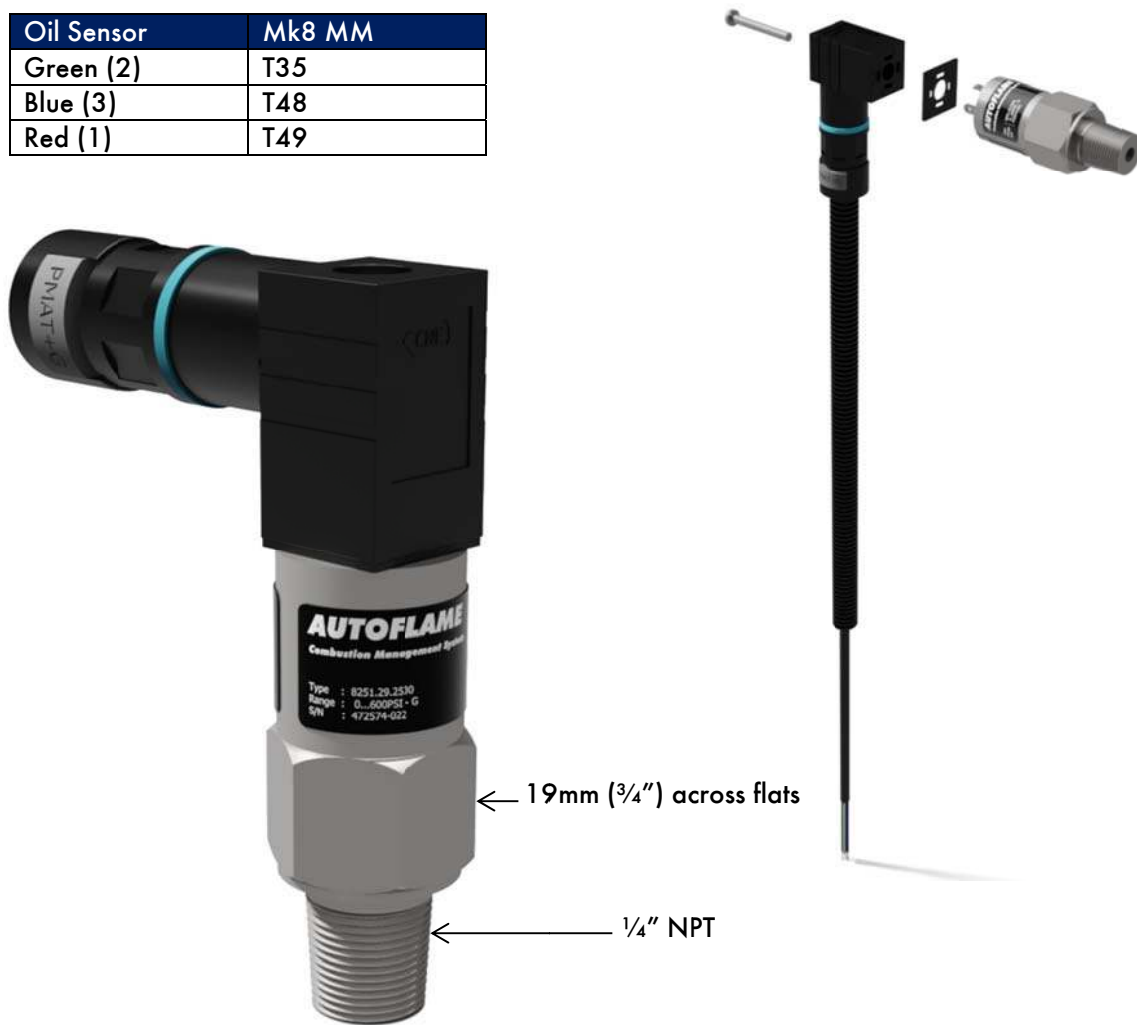

Drawing No. 9002

IP	65
NEMA	4
Torque setting	Max 25Nm
O-Ring material	Viton
Storage Temperature	-25 to 85°C (-13 to 185°F)
Operating Temperature	-25 to 85°C (-13 to 185°F)
Media Temperature	-25 to 125°C (-13 to 257°F)
Operating Range	0 to 40 Bar (0 to 600 PSI)
Over Pressure Rating	80 Bar (1160 PSI)
Burst Pressure Rating	290 Bar (4350 PSI)

Maximum 2.5mm flat blade screw driver for electrical connection.  
 Plug fits correctly in one position only, do not force.  
 Do not use case to tighten pressure connection.

Oil Pressure Sensor

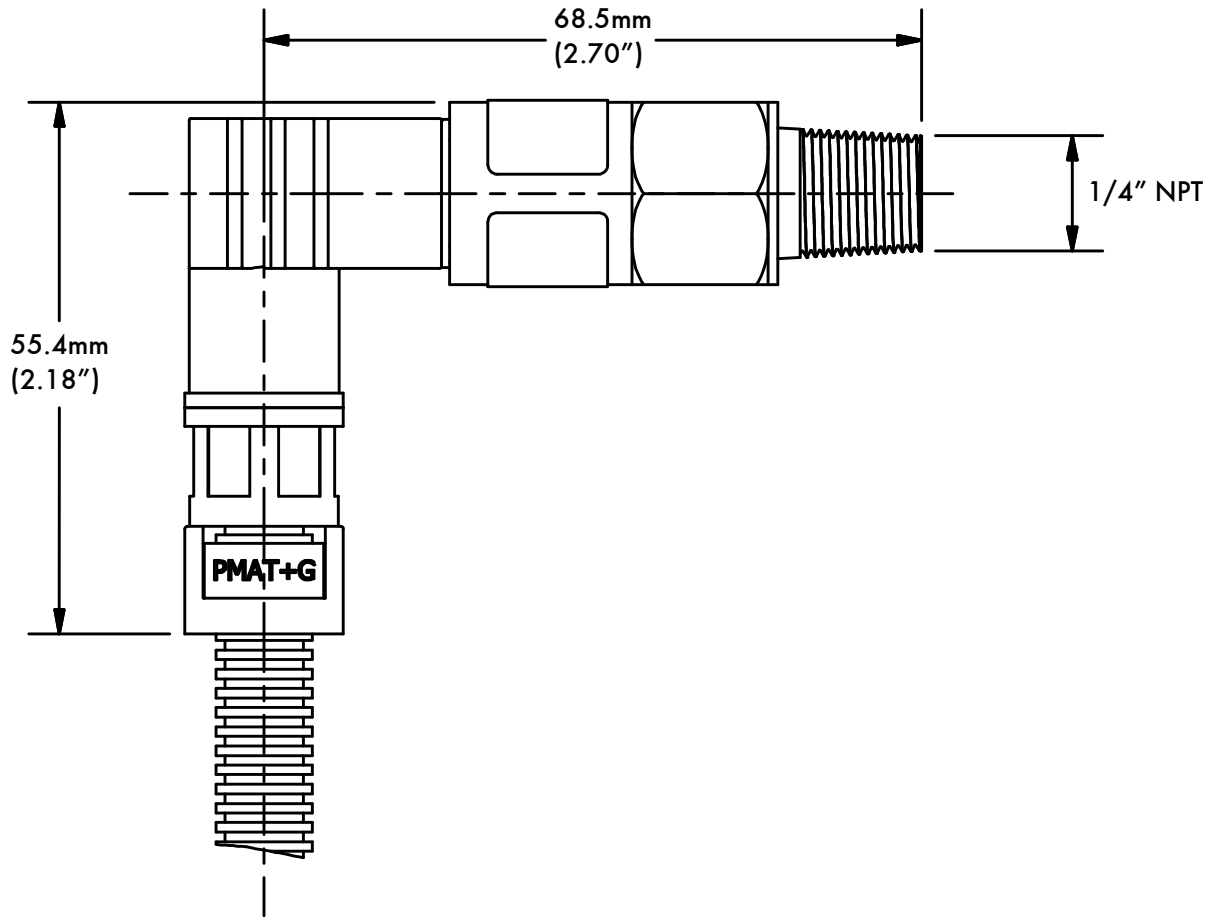

**Note:** Flying lead supplied length 1.5m (PMA 1m).

Mk8 MM

If the oil pressure sensor is being used, the following options/parameters need to be set.

Option/Parameter	Mk8 MM
125	Fuel pressure sensor mode – fuel 1
126	Fuel pressure sensor mode – fuel 2
127	Fuel pressure sensor mode – fuel 3
128	Fuel pressure sensor mode – fuel 4
139	Oil pressure switch – offset lower limit
140	Oil pressure switch – offset upper limit
Parameter 42	Oil pressure units